

PTF080D3

Photo Transistor

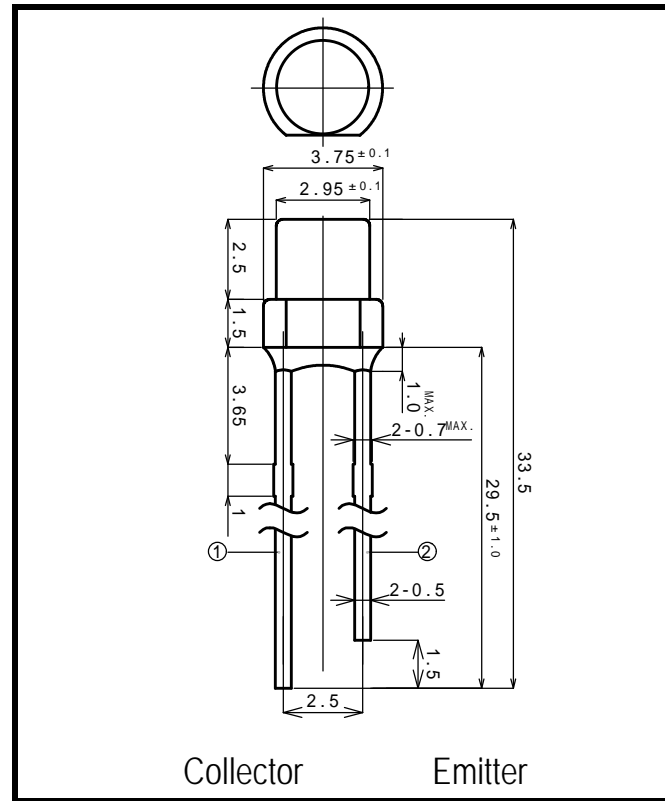

FEATURES • High Reliability in Demanding Environments

- Wide Angular Response
- Compact

APPLICATIONS • Optical Switches
• Edge Sensing
• Fiber Optical Communications
• Smoke Detectors

Collector Emitter
Dimensions (Unit:mm)

2. ELECTRICAL & OPTICAL CHARACTERISTICS (Ta=25 °C)

ITEM	SYMBOL	CONDITIONS	MIN	TYP	MAX	UNIT
Collector Emitter Current	I _{cel}	V _{ce} =10V, L=0.5mW/cm ²		0.5		mA
Collector Dark Current	I _{ceo}	V _{ce} =10V			100	nA
C-E Saturation Voltage	V _{CE(sat)}	I _c =0.2mA, L=5.0mW/cm ²		0.2		V
Spectral sensitivity				450 ~ 1050		nm
Peak Sensitivity Wave Length	λ _p			880		nm
Switching time (Rise Time)	T _r	R _L =1000 Ω, V _{cc} =5V, I _c =1mA		20.0		μs
Switching time (Fall Time)	T _f	R _L =1000 Ω, V _{cc} =5V, I _c =1mA		20.0		μs
Angular Response				±65		deg

Color Temperature=2870°K Standard Tungsten Lump

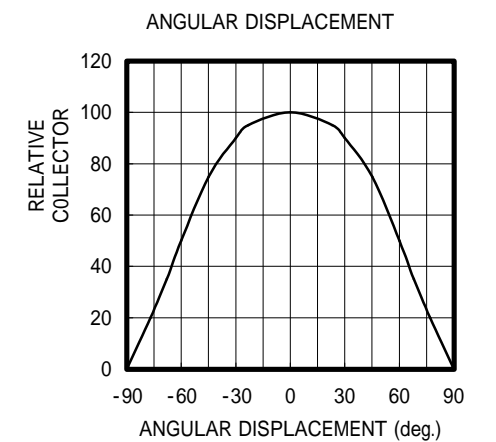
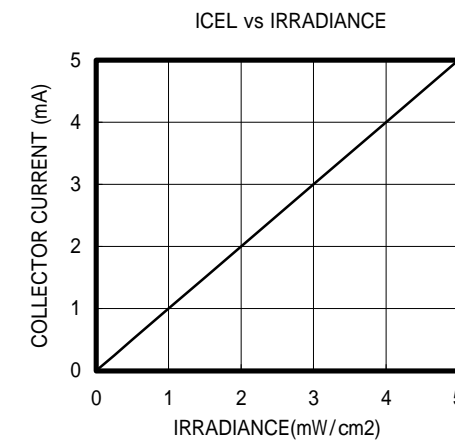
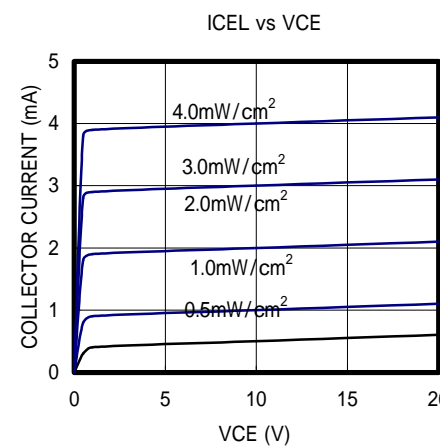

1. ABSOLUTE MAXIMUM RATINGS (Ta=25 °C)

ITEM	SYMBOL	RATINGS	UNIT
Collector-Emitter Voltage	V _{ceo}	30	V
Emitter-Collector Voltage	V _{eco}	5	V
Collector Current	I _c	50	mA
Collector Power Dissipation	P _c	200	mW
Operating Temp.	T _{opr}	-20 TO 85	
Storage Temp.	T _{stg}	-30 TO 100	
Junction Temp.	T _j	100	
Lead Soldering Temp.*	T _{ls}	260	

*Time 5 Sec max, Position: Up to 3mm from the body

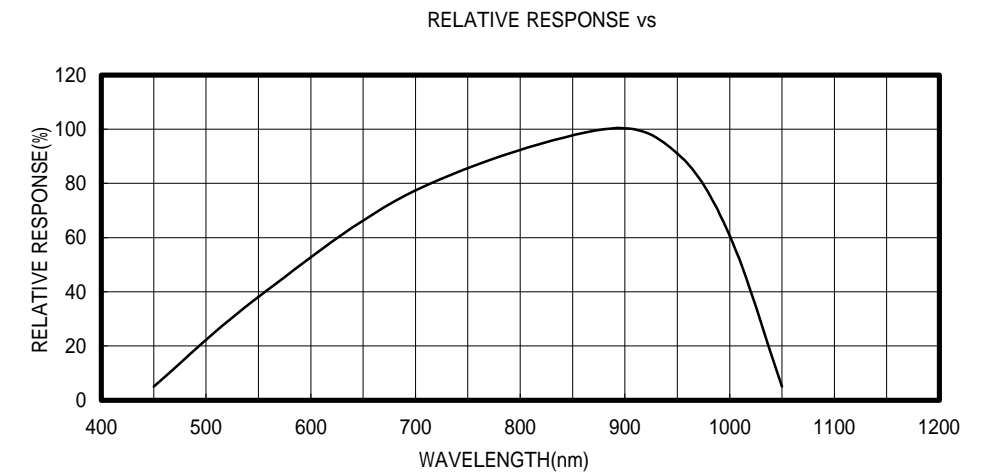
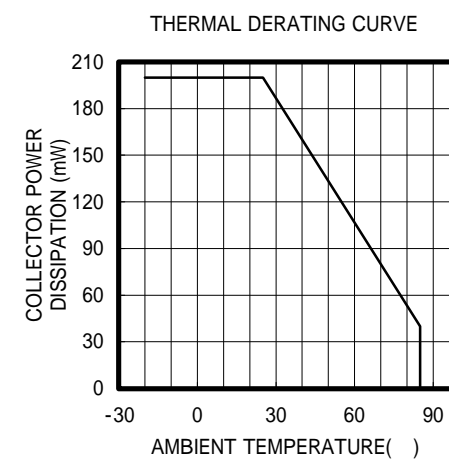

OPTRANS

2-6-11 MASUKATA, TAMA-KU, KAWASAKI 214-0032, JAPAN
TEL.81(44)932-6491 / FAX.81(44)932-8281
E-mail: oprans@mb.kcom.ne.jp