

VSC644M3A

Visible Light Emitting Diode

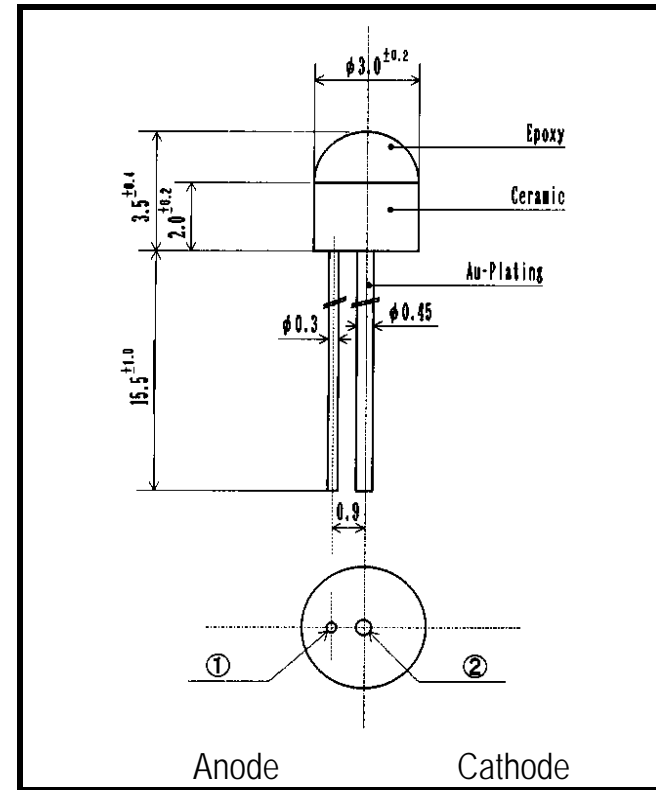

- FEATURES**
- High-output Power
 - Wide Viewing Angle
 - Compact
- APPLICATIONS**
- Display
 - Indicators
 - Light-source for Sensor
 - Optical Switches

1. ABSOLUTE MAXIMUM RATINGS(Ta=25 °C)

ITEM	SYMBOL	RATINGS	UNIT
Forward Current (DC)	IF	30	mA
Forward Current (Pulse)*1	IFP	0.3	A
Reverse Voltage	VR	5	V
Power Dissipation	PD	75	mW
Operating Temp.	Topr	-20 TO 80	
Storage Temp.	Tstg	-30 TO 100	
Junction Temp.	Tj	100	
Lead Soldering Temp.*2	Tls	260	

*1:Tw=10uS,T=10mS

*2:Time 5 Sec max,Position:Up to 3mm from the body

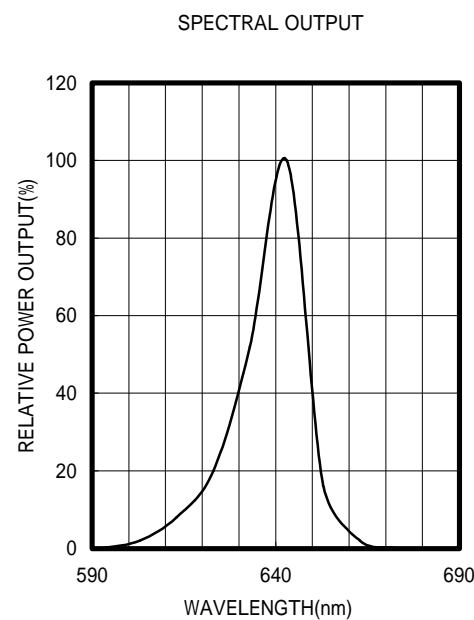

2. ELECTRICAL & OPTICAL CHARACTERISTICS (Ta=25 °C)

ITEM	SYMBOL	CONDITIONS	MIN	TYP	MAX	UNIT
Power Output	PO	IF=20mA	2.0	4.0		mW
Forward Voltage	VF	IF=20mA		2.0	2.4	V
Reverse Current	IR	VR=5V			100	μA
Peak Wavelength	λp	IF=20mA		643		nm
Spectral Line Half Width		IF=20mA		18		nm
Half Intensity Beam Angle		IF=20mA		±80		deg.
Rise Time	Tr	IFP=20mA		-		nS
Fall Time	Tf	IFP=20mA		-		nS
Junction Capacitance	Cj	1MHz, V=0V		20		pF
Temp. Coefficient of PO	P/T	IF=10mA		-0.8		%/°C
Temp. Coefficient of VF	V/T	IF=10mA		-1.5		mV/°C

