

VS657B

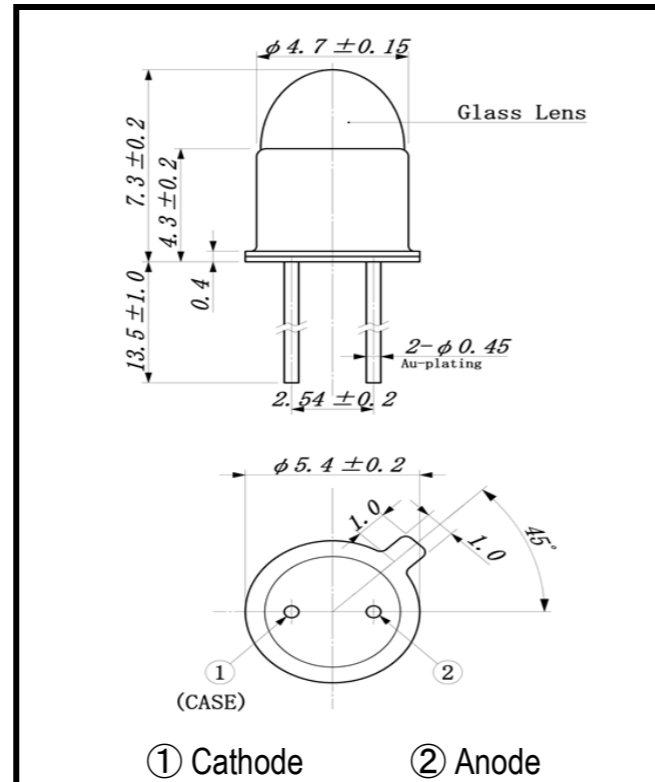
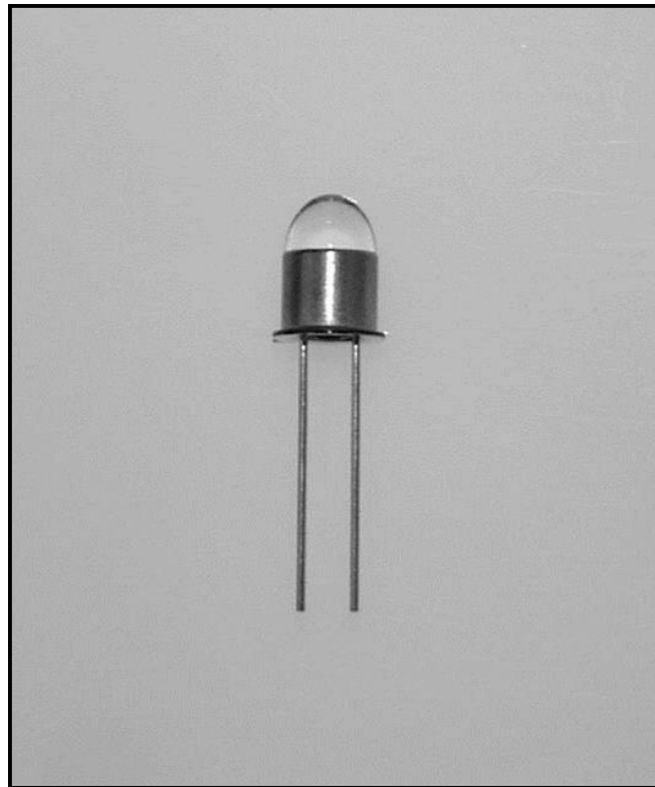

FEATURES

- Red Color Point-Source LED
- Emitting Window Dia. ϕ 150 μ m

APPLICATIONS

- Optical Switches
- Linear & Rotary Encoder

1. ABSOLUTE MAXIMUM RATINGS (Ta=25°C)

ITEM	SYMBOL	RATINGS	UNIT
Forward Current (DC)	IF	50	mA
Forward Current (Pulse)*1	IFP	0.3	A
Reverse Voltage	VR	5	V
Power Dissipation	PD	125	mW
Operating Temp.	Topr	-20 TO 85	°C
Storage Temp.	Tstg	-30 TO 100	°C
Lead Soldering Temp.*2	Tls	260	°C

*1: Tw=10uS, T=10mS

2. ELECTRICAL & OPTICAL CHARACTERISTICS (Ta=25°C)

ITEM	SYMBOL	CONDITIONS	MIN	TYP	MAX	UNIT
Power Output	PO	IF=20mA		1.0		mW
Forward Voltage	VF	IF=20mA		1.9	2.4	V
Reverse Current	IR	VR=5V			10	μ A
Peak Wavelength	λ_p	IF=20mA		650		nm
Spectral Line Half Width	$\Delta \lambda$	IF=20mA		5		nm
Half Intensity Beam Angle	θ	IF=20mA		± 3		deg.

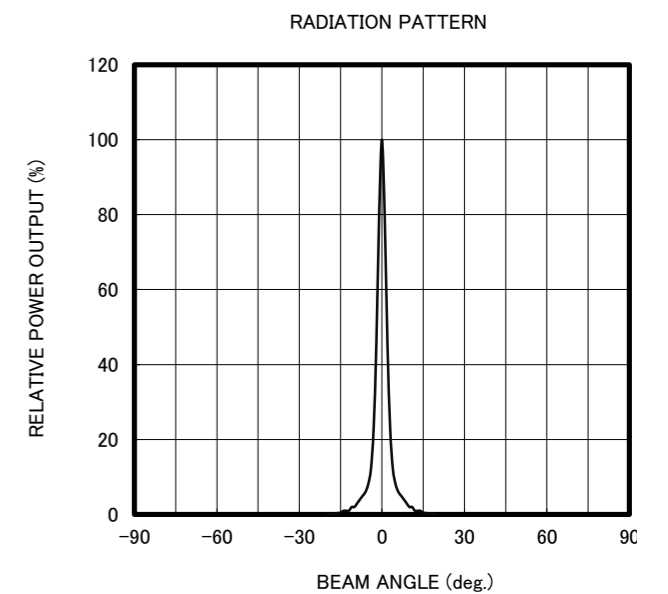
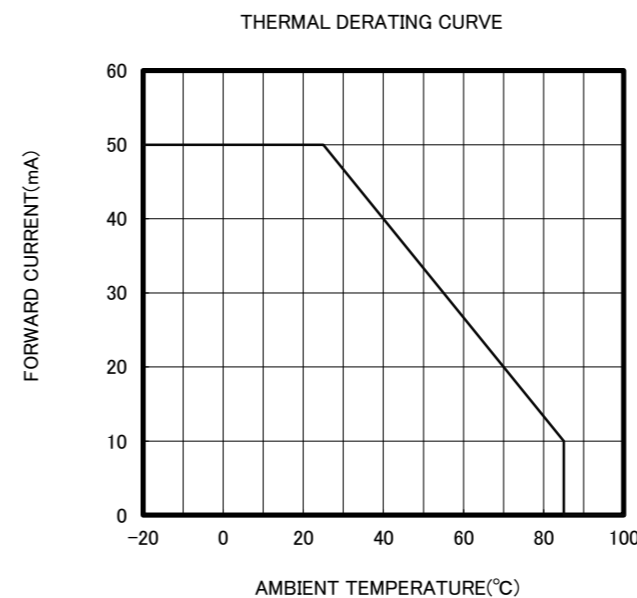
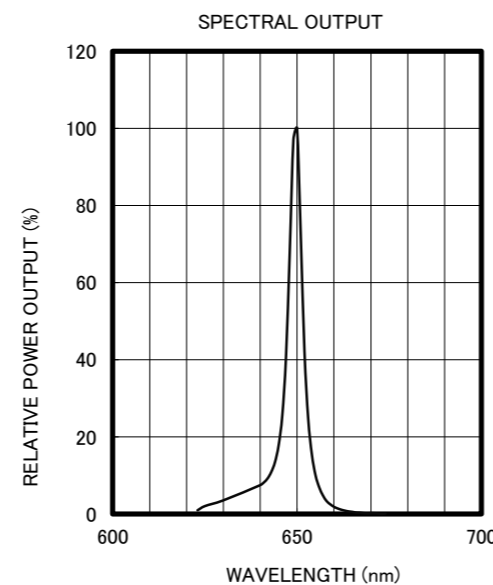
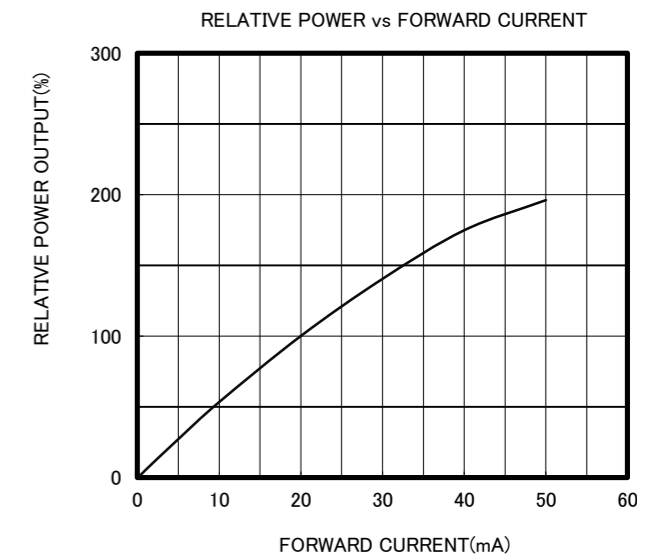
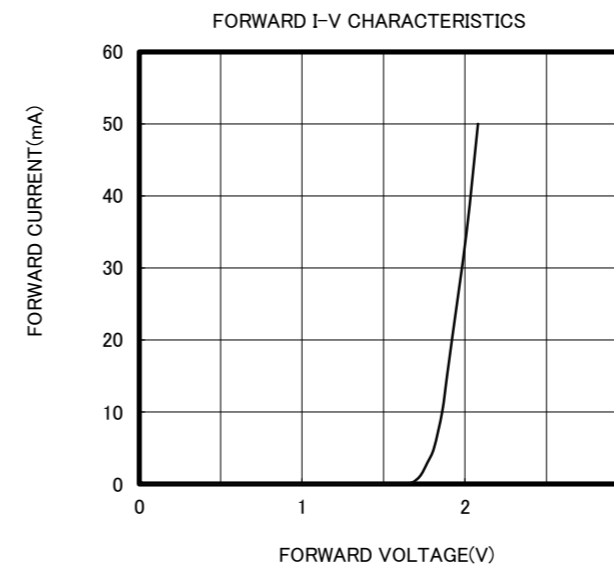

OPTRANS

241, NOBORITO, TAMA-KU, KAWASAKI 214-0014, JAPAN
 TEL.81(44)932-6491 / FAX.81(44)932-8281
 E-mail optrans@optrans.com